

## MCW ATEX SUSPENDED CRANE SCALES

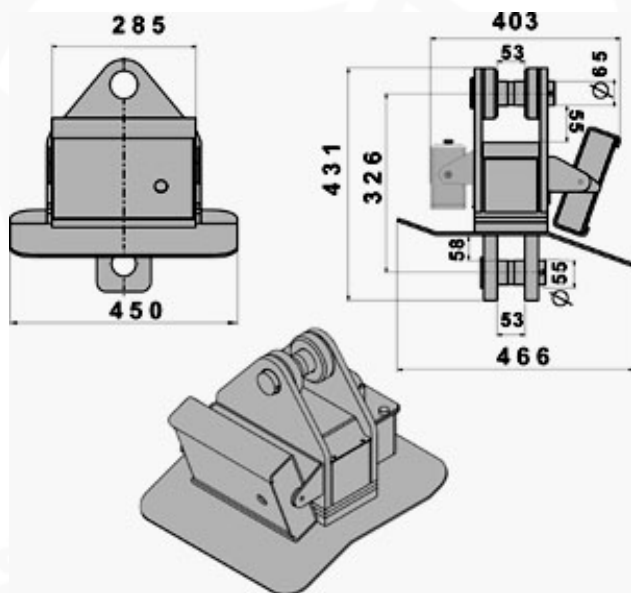

MCWATEX with optional ring and swivelling hook



MCWATEX - dimensions in mm

**Industrial crane scales for use in areas classified as hazardous (Zone 1 and 2) in accordance with Ex II 2G IIC T4 protection.**

**LITTLE SPACE IS TAKEN UP** allowing the best use of the lifting devices.

**Predisposed for an upper connection ring and lower hook.**

### MAIN FEATURES

- Indicator with 16-key waterproof functional keyboard and fitted with **CESI 04 ATEX 102 EC-Type-Examination certificate**.
- LCD display with 6 25-mm high contrast digits and icons for showing the active functions.
- Precision:  $\pm 0.03\%$  F.S.
- Built extremely sturdy in oven-fire painted sheet steel.
- Digital set-up and calibration programmable directly from keyboard using a sample weight.
- Operating temperature:  $-10 / +70$  °C.
- Programmable digital filter and auto power saving function.
- Hermetically sealed rechargeable battery, with 160-hour operating time; rechargeable in safe area.
- Equipped with 230Vac 50 Hz battery charger to be used in safe area.

### FUNCTIONS

- **KEYBOARD:** Zeroing, Automatic Tare, Presetable Tare, ID1 and ID2 10-digit Codes, Print and data transmission commands, selectable function command, on/off switching
- **SELECTABLE FUNCTIONS:** Simple display and/or with sensitivity HR x 10, Net/Gross, Input/Output, Weighs accumulation (with up to 10 storage values). Tare database (up to 10), Formula weighing, Counting (Max. Resolution of 1.500.000 divisions) with function of entering the known A.P.W., lb/kg conversion, Hold, Set-point on gross weight, set-point on net weight.

### OPTIONS ONLY AVAILABLE AT TIME OF ORDER

- Rechargeable battery pack

### Available versions

| Code      | Max Capacity | Division kg | Price € |
|-----------|--------------|-------------|---------|
| MCWATEX6  | 6000         | 1           | 3500.00 |
| MCWATEX10 | 10000        | 2           | 3500.00 |
| MCWATEX15 | 15000        | 2           | 3800.00 |
| MCWATEX25 | 25000        | 5           | 4000.00 |
| MCWATEX35 | 35000        | 10          | 4950.00 |

### Options only available at time of order

| Code        | Description   | Price (€) |
|-------------|---|-----------|
| DFWBP76ATEX | Rechargeable ATEX battery pack, for weight indicator, pallet truck scale, or crane scale.<br>NOTE: in the applications with the weight indicator mounted on a column or cart, the installation requires the STFA bracket. | 475,00    |
| UKPLUG      | Power adapter from Schuko to BS1363.  | 15,00     |

**Accessories**

| Code   | Description   | Price (€) |
|--------|---|-----------|
| GG15   | Swivelling bottom hook with safety lock 15 t                          | 330,00    |
| GG22   | Swivelling bottom hook with safety lock 22 t                          | 700,00    |
| GG30   | Swivelling bottom hook with safety lock 30 t                          | 2000,00   |
| CA15   | Connection ring 15 t  | 50,00     |
| CA30   | Connection ring 30 t  | 165,00    |
| CA40   | Connection ring 40 t  | 225,00    |
| TECMAN | Printed technical manual (free, if downloaded from the web) NET PRICE | 15,00     |
| UMAN   | Printed user manual (free, if downloaded from the web) NET PRICE      | 5,00      |

**MEASUREMENTS OF HOOKS AND RINGS IN MM**

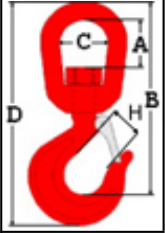
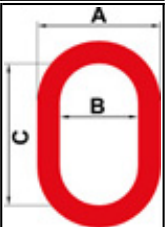
|  | Code        | A   | B   | C   | D   | H  |
|--|-------------|-----|-----|-----|-----|----|
|  | <b>GG15</b> | 95  | 354 | 96  | 455 | 63 |
|  | <b>GG22</b> | 121 | 432 | 120 | 565 | 80 |
|  | <b>GG30</b> | 133 | 568 | 139 | 667 | 88 |
|  | <b>CA15</b> | 174 | 110 | 200 |     |    |
|  | <b>CA30</b> | 270 | 180 | 340 |     |    |
|  | <b>CA40</b> | 292 | 190 | 350 |     |    |

**Mobile Weighing price list MARCH 2008**  
**Category M08 ver 1.1**

Dini Argeo S.r.l. -  
P.IVA/VAT IT 00767800360  
Copyright 2002-2008 - All Rights Reserved.  
[www.diniargeo.com](http://www.diniargeo.com)