



KERN VOB

Version 1.1 2/2007

Operating Instructions Hand truck scale

Table of contents

1	TECHNICAL DATA.....	20
2	DECLARATION OF CONFORMITY	21
3	FUNDAMENTAL INFORMATION CONCERNING THE SCALE	22
3.1	Intended use.....	22
3.2	Inappropriate use	22
3.3	Guarantee.....	22
3.4	Monitoring of the weighing mechanism.....	23
4	FUNDAMENTAL SAFETY INFORMATION CONCERNING THE SCALE	23
4.1	Observe the information contained in the operating instructions.....	23
4.2	Staff training	23
5	TRANSPORT AND STORAGE.....	23
5.1	Acceptance check	23
5.2	Packaging.....	23
6	UNPACKING, INSTALLATION AND COMMISSIONING	24
6.1	Place of installation and use of the scale	24
6.2	Scope of delivery	24
6.3	Mains supply.....	25
6.4	Operation with power supply from the battery.....	25
6.5	Initial start-up	25
6.6	Transformation of sack barrow into hand truck.....	26
6.7	Information concerning the pushbuttons.....	27
6.8	Adjustment.....	28
7	OPERATION	29
7.1	Weighing.....	29
7.2	Taring	30
7.3	Hold function (function for weighing of animals)	31
7.4	Plus/minus weighing.....	31
7.5	Weighing unit.....	32
8	MAINTENANCE, UPKEEP, DISPOSAL	33
8.1	Cleaning	33
8.2	Maintenance, upkeep	33
8.3	Disposal.....	33
9	TROUBLESHOOTING	34

1 Technical data

KERN	VOB 150K100
<i>Readout (d)</i>	100 g
<i>Weighing range (max.)</i>	150 kg
<i>Warm-up time (operating temperature)</i>	10 min
<i>Reproducibility</i>	100 g
<i>Linearity</i>	± 200 g
<i>Stabilization time</i>	2 sec
<i>Recommended calibration weight, not included (class)</i>	100 kg (M3)
<i>Permissible ambient temperature</i>	0° C + 40° C
<i>Air humidity</i>	max. 85 % (not condensing)
<i>Weighing units</i>	kg, lb
<i>Size of weighing plate, lacquered steel</i>	914 x 470 mm
<i>Auto Off</i>	3 min
<i>Battery</i>	Time of operation: 14 h Time of charging: 14 h

2 Declaration of conformity



KERN & Sohn GmbH

D-72322 Balingen-Frommern

Postfach 4052

E-Mail: info@kern-sohn.de

Tel: 0049-[0]7433- 9933-0

Fax: 0049-[0]7433-9933-149

Internet: www.kern-sohn.de

Konformitätserklärung

Declaration of conformity for apparatus with CE mark

Konformitätserklärung für Geräte mit CE-Zeichen

Déclaration de conformité pour appareils portant la marque CE

Declaración de conformidad para aparatos con marca CE

Dichiarazione di conformità per apparecchi contrassegnati con la marcatura CE

Deklaracja zgodności dla urządzeń z oznaczeniem CE

- English** We hereby declare that the product to which this declaration refers conforms with the following standards.
- Deutsch** Wir erklären hiermit, daß das Produkt, auf das sich diese Erklärung bezieht, mit den nachstehenden Normen übereinstimmt.
- Français** Nous déclarons avec cela responsabilité que le produit, auquel se rapporte la présente déclaration, est conforme aux normes citées ci-après.
- Español** Manifestamos en la presente que el producto al que se refiere esta declaración está de acuerdo con las normas siguientes
- Italiano** Dichiariamo con ciò che il prodotto al quale la presente dichiarazione si riferisce è conforme alle norme di seguito citate.
- Polski** Niniejszym oświadczamy, że produkt, którego dotyczy ta deklaracja, jest zgodny z poniższymi normami.

Electronic Scale: KERN VOB

Mark applied	EU Directive	Standards
	89/336EEC EMC	EN 50081-1 : 1992 EN 50082-1 : 1998

Date: 17. Nov. 2006

Signature:

Gottl. KERN & Sohn GmbH
Management

Gottl. KERN & Sohn GmbH, Ziegelei 1, D-72336 Balingen, Tel. +49-[0]7433/9933-0, Fax +49-[0]7433/9933-149

3 Fundamental information

3.1 Intended use

The scale you have purchased serves to determine the weighing value of a certain object. It is intended to be used as a „non-automatic” scale, i.e. the object to be weighed is manually and carefully placed as close to the centre of the weighing plate as possible. The weighing value can be read after a stable weighing value has been obtained.

3.2 Inappropriate use

Do not use the scale for dynamic weighing. In the event that small quantities are removed or added onto the weighing plate, incorrect results can be displayed due to the “stability compensation” in the scale! (Example: slowly leaking liquids from a container on the weighing plate.)

Do not leave a permanent load on the weighing plate.

Be sure to avoid impact shock and overloading the scale in excess of the prescribed maximum load rating, minus any possible tare weight that is already present.

This could cause damage to the scale.

Never operate the scale in locations with explosion hazards. The serial version of the scale is not explosion proof.

Structural alterations may not be made to the scale. This can lead to incorrect weighing results, technical faults or destruction of the scale.

The scale may only be used in compliance with the described guidelines.

Different operating ranges or areas of the scale require prior written approval of KERN.

3.3 Guarantee

The guarantee expires following:

- the user’s failure to observe the guidelines contained in the operating instructions
- use of the scale outside the described operating range or area of the scale
- alteration to or opening of the device
- mechanical damage, damage by the media or liquids
- natural wear and tear
- inappropriate assembly or connection to the power supply installation
- overloading of the measuring mechanism.

3.4 Monitoring of the weighing mechanism

The metrology characteristics of the scale and any possible calibration weights must be checked at regular intervals for the purposes of quality assurance.

A responsible user is able to individually determine the method and scope of monitoring. Information with regard to monitoring of the scale's weighing mechanism as well as calibration weights is available at KERN's website (www.kern-sohn.com). The calibration weights and scales can be calibrated quickly and at a reasonable price at KERN's accredited laboratory (in accordance with national norms).

4 Fundamental safety information

4.1 Observe the information contained in the operating instructions

Please read the operating instructions carefully prior to installation and commissioning, even if you already have experience with KERN scales.

4.2 Staff training

The device may only be operated and maintained by trained staff.

5 Transport and storage

5.1 Acceptance check

Please check the packaging immediately upon delivery and the device during unpacking for any visible signs of external damage.

5.2 Packaging

Please retain all items of the original packaging in case it should be necessary to return the device.

Only the original packaging should be used for return consignments.

Before despatch, disconnect all attached cables and movable parts.

6 Unpacking, installation and commissioning

6.1 Place of installation and use of the scale

The scale is constructed in such a way that reliable weighing results can be achieved under normal operating conditions.

By selecting the correct location for your scale, you will be able to work quickly and precisely.

Please take the following issues into account while selecting the place of installation:

- Correct operation of the scale is only possible in case of horizontal positioning of the truck (stable, robust position on 4 wheels);
- The hand truck scale ought to be placed on a firm and even surface;
- Avoid extreme heat and temperature fluctuations which can take place, for example, if the scale is installed next to a heater or when exposed to direct sunlight;
- Protect the scale against direct draughts caused by open windows and doors;
- Avoid jarring during weighing;
- Protect the scale against excessive humidity, vapours and dust;
- Do not expose the device to high humidity for longer periods of time. Inadmissible bedewing (condensation of air moisture on the device) can occur if a cold device is taken into a significantly warmer environment. In this case, condition the device for approx. 2 hours at room temperature;
- Avoid static charging of the material to be weighed, weighing containers and the draught shield.

In case of occurrence of electromagnetic fields (e.g. caused by cellular phones or wireless equipment), static charging or unstable power supply, major display deviations are possible (incorrect weighing results). It is then necessary to change the location of the scale or remove the source of interference.

6.2 Scope of delivery

Serial equipment:

<i>KERN VOB</i>
<ul style="list-style-type: none">• <i>Hand truck scale</i>• <i>Power supply adapter</i>• <i>Operating instructions</i>

6.3 Mains supply

Electricity supply takes place from the external electricity feeder. The printed voltage level must comply with local voltage.

Use original KERN electricity feeders only. The use of other makes is subject to approval by KERN.

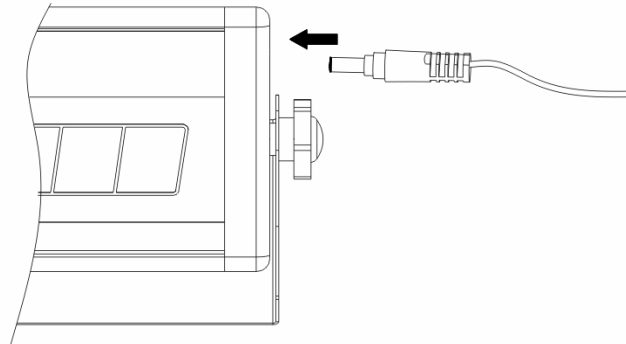

6.4 Operation with power supply from the battery

The internal battery is charged through the feeder included in the delivery.

Prior to first use, the battery ought to be charged by means of the feeder for at least 14 hours. The working time of the battery is ca. 14 hours; the time of charging until full capacity is ca. 14 hours.

In order to save the battery, the scale switches off automatically 3 minutes after weighing.

If the display [L o] indicates the battery is empty, connected the feeder in order to recharge the battery.

6.5 Initial start-up

In order to obtain exact weighing results with electronic scales, the scale must reach the operating temperature (see warming up time, chapter 1). During the warm-up time, the scale must be connected to the power supply (mains, battery).

Accuracy of the scale depends on local gravitational acceleration.

Please be sure to observe the guidelines contained in the chapter on calibration.

6.6 Transformation of sack barrow into hand truck

1. Place the barrow on the ground

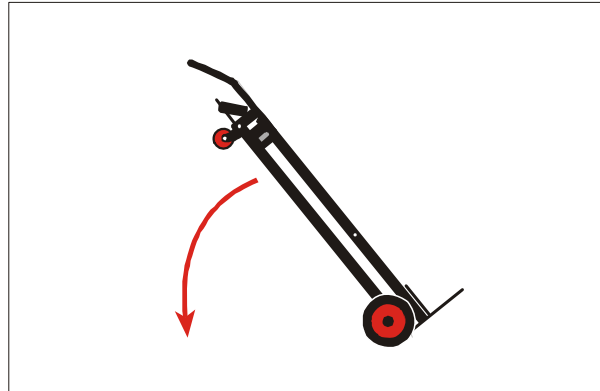

2. Unlock safety pins (1) to remove the handle (2)

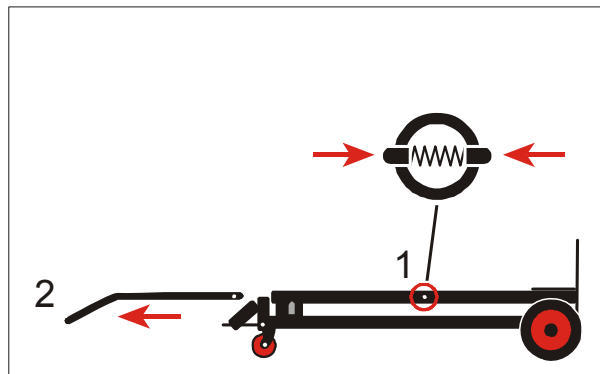



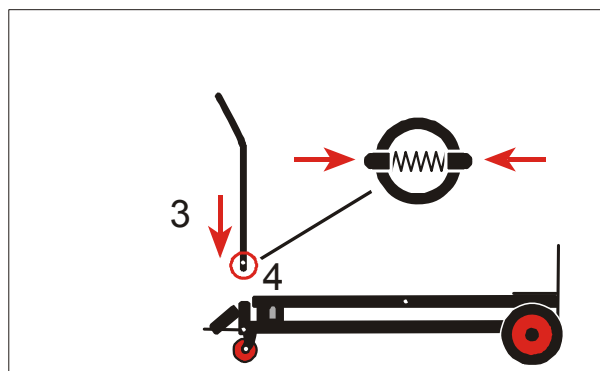

3. Insert the handle (3) and lock it (4). Make sure latches do not engage in the safety pins.

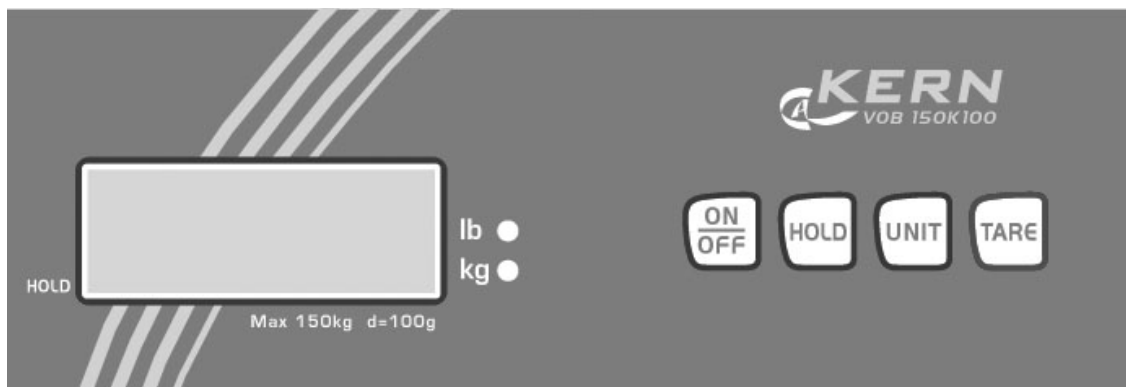

6.7 Information concerning the pushbuttons



	Switch on / switch off
	Reset of tare or of displayed readout
	Change of weighing unit
	Hold function (function for weighing of animals)

6.8 Adjustment

As the gravitational acceleration is not the same in every location on earth, each scale – in compliance with the underlying physical weighing principle – must be adjusted at the place of installation to the gravitational acceleration at that location (only if the scale has not been adjusted to the location conditions at the factory).



This adjustment process must be carried out during initial start-up, after change of location and in case of variation in ambient temperature. It is also recommended to adjust the scale periodically during weighing operations in order to obtain exact measured values.

6.9 Adjusting

Using calibration weights, accuracy of the scale can be checked and adjusted at any time.

Adjusting procedure:

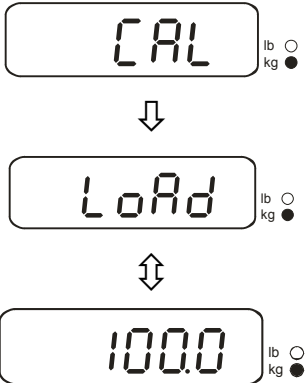
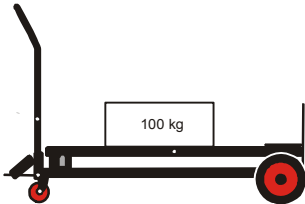
Make sure the ambient conditions are stable. Observe the warm-up time (see chapter 1) in order to stabilise the device. Calibration may be performed in horizontal position of the truck (stable positioning on 4 wheels):

<p>Press the “UNIT” pushbutton and hold it until the exact weight of the adjusting weight blinks on the display; moreover, “Load” appears on the display.</p>	
<p>Place the adjusting weight exactly in the centre of the weighing plate.</p>  <p>Press UNIT key . Within a while the value of the adjusting weight will stabilise.</p>	
<p>Remove the adjusting weight; the scale will automatically return to the weighing mode.</p>	

Adjusting weights are to be stored together with the scale. Daily monitoring of the scale’s accuracy is recommended in order to maintain high quality of measurement.

7 Operation



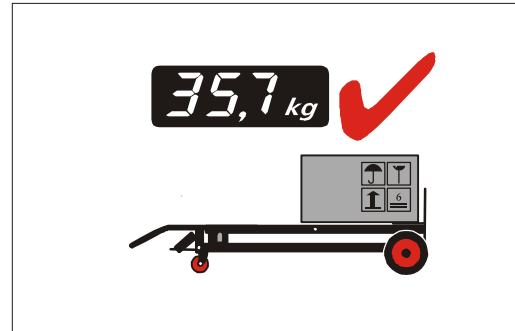
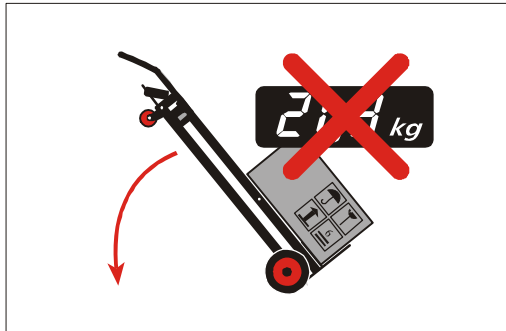

Note: Optimal operation of the scale is only guaranteed in case of horizontal positioning of the truck (stable position on 4 wheels). In case of different positioning of the device, the weighing results will be incorrect.



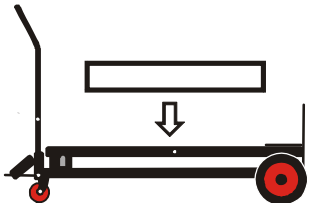

7.1 Weighing

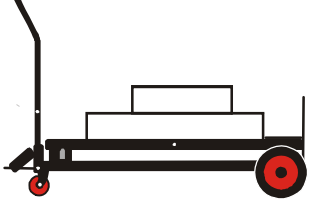
<p>Switch on the scale with the “ON/OFF” pushbutton. The scale will carry out self-test.</p> <p>As soon as „0.0” appears on the display, the scale is ready for weighing.</p> <p>Note: if the display reading blinks or does not show „0”, press the “TARE” pushbutton.</p>	
<p>Place the object to be weighed. Its weight value will be displayed:</p>	
<p>The user may switch to a different weighing unit by pressing the “UNIT” pushbutton:</p> <p style="text-align: center;">[kg] → [lb] → [kg]</p>	

7.2 Taring

<p>Switch on the scale by means of the “ON/OFF” pushbutton and wait for „0“ readout.</p>	
<p>Place an empty container on the weighing plate.</p>  <p>The weight of the container will be displayed.</p>	
<p>Press the “TARE” pushbutton, the scale will display „0“: The weight of the container is now recorded in the scale.</p>	
<p>Place the object to be weighed inside the container.</p>  <p>Read the weight of the weighed object from the display.</p>	

The taring process may be repeated many times, e.g. during weighing of many ingredients for a mixture.

<p>Press the “TARE” pushbutton, the scale will display „0“: The total weigh of the container will be tared.</p>	
<p>Add new ingredients into the container (adding of weight). Now read the weight of the added item from the display.</p>	

Notes:

The scale may only record one value of packaging weight.

After removing all objects, the scale will display the recorded value of the packaging as a negative value.



In order to remove the recorded value of the packaging weight, remove all objects from the weighing plate and press the “**TARE**” pushbutton.

The taring process may be repeated any number of times. The limit will be reached upon exceeding the total weighing range.

7.3 Hold function (function for weighing of animals)

The scale has a built-in function for weighing animals (averaged value). Pets and other small animals (load of minimum 1% of the maximum load) may be weighed on the scale, even though those animals cannot stand still on the weighing plate.

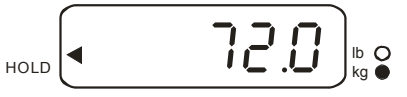

Note: In case of very lively animals (high fluctuations of weighing readouts), the averaged value cannot be obtained.

<p>Switch on the scale with the “ON/OFF” pushbutton and wait for „0“ readout.</p>	
<p>Place the object to be weighed (animal) on the weighing plate and confirm this by pressing the “HOLD” pushbutton. A triangle blinks in the left hand side of the display; the scale now records numerous weight values and then displays the averaged value.</p>	
<p>Return to the weighing mode by pressing the “HOLD” pushbutton.</p>	
<p>The function may be repeated by pressing the “HOLD” pushbutton again.</p>	

7.4 Plus/minus weighing

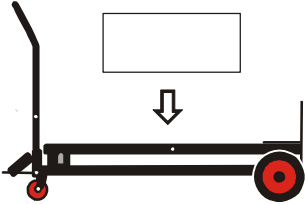
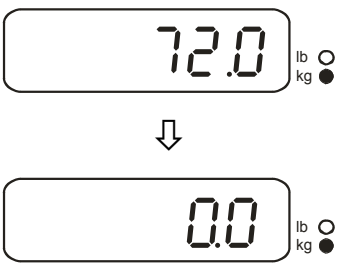
For example: in order to monitor the weight of particular items of a given object or for the purpose of final control, etc.



<p>Switch on the scale with the “ON/OFF” pushbutton and wait for „0“ display.</p>	
<p>Place the master weight (object) and tare the scale by means of the “TARE” pushbutton to „0“.</p> 	

<p>Remove the master weight.</p> <p>Place subsequent objects to be monitored on the weighing plate; each deviation from the recorded master value will be displayed by means of „+“ and „-“ readouts.</p> <p>The weight of particular items of packaging may be checked in the same way, by relating it to the master weight.</p>	 <p style="text-align: center;">bzw.</p> 
<p>The function may be repeated by pressing again the “HOLD” pushbutton.</p>	

7.5 Weighing unit

Two weighing units are available: „kg“ and „lb“.

The unit is each time indicated by the lamp on the right hand side of the display.

<p>Switch on the scale with the “ON/OFF” pushbutton and wait for „0“ display.</p>	
<p>Place the object to be weighed on the weighing plate, the weight value will be displayed.</p> <p>The weight unit is selected by means of the „Unit“ pushbutton.</p> <p>Unit recalculation: 1 kg = 2.20462 lb</p>	 

8 Maintenance, upkeep, disposal

8.1 Cleaning

Disconnect the device from mains supply before cleaning.

Do not use aggressive cleaning agents (solvents, etc.), but a cloth dampened with mild soap. Make sure liquids do not penetrate into the device; to avoid this, wipe the device with a dry and soft cloth.

Loose residues / powders are to be removed carefully with tweezers or hand held vacuum cleaner.

Immediately remove any spilt material to be weighed.

8.2 Maintenance, upkeep

The device may only be opened by trained service engineers authorised by KERN. Disconnect the device from the mains supply before opening.

8.3 Disposal

Disposal of the packaging and the device should be performed in compliance with valid laws of the operating location.

9 Troubleshooting

In case of error in the programme, the scale is to be switched off and disconnected from the mains supply for a short time. The weighing process is to be repeated from the beginning.

Help:

Error

Possible cause

Weight display is not illuminated.

- *The scale is not switched on.*
- *Mains supply has been interrupted (mains cable not plugged in / damaged).*
- *No power supply.*

Weight display changes continually.

- *Draught / air movement*
- *Vibrations*
- *Influence of foreign matter on the weighing plate*
- *Electromagnetic fields / static charging (choose a different location / switch off source of interference if possible).*

Weighing result is incorrect.

- *Scale has not been reset.*
- *Scale requires adjustment.*
- *Great fluctuations in temperature.*
- *Electromagnetic fields / static charging (choose a different location / switch off source of interference if possible).*

In case of other errors, switch the scale off and then switch it on again.
If the error maintains, contact the manufacturer.