

RAVAS-1

LOAD INDICATION SYSTEM



REVOLUTIONARY, PATENTED CONCEPT FROM THE LEADER IN MOBILE WEIGHING

NO SCALE COMPONENTS MOUNTED IN THE FORKS: VIRTUALLY INDESTRUCTIBLE

ORIGINAL FORK DIMENSIONS: EASY ENTRANCE INTO LOW PALLETS AND CONTAINERS

FOR SIMPLE CHECK WEIGHING: ON BOARD LORRIES, AT GOODS RECEPTION, DETERMINING SHIPPING WEIGHTS, AVOIDING OVERLOADS

WEIGHT INDICATION IN 5 KG STEPS, TOLERANCE 0.8% OF FULL SCALE: ± 20 KG

STANDARD SUPPLIED WITH QUICK LIFT PUMP

POWERED BY STANDARD AA-BATTERIES FOR 3000 WEIGHINGS

LOW POWER CONSUMPTION; AUTOMATIC SWITCH-OFF

FUNCTIONS

- Automatic and manual zero correction
- Gross/net weighing
- Push button tare over full scale capacity
- Error messages in display
- Automatic switch-off after 3 minutes of non-use



Weighing at reference height only

DIMENSIONS

A Fork length	:	1150 mm
B Fork width	:	150 mm
C Minimum fork height	:	83 mm
Minimum space between floor and forks	:	30 mm
D Maximum fork height	:	205 mm
Lifting height	:	122 mm
E Width over forks	:	520 mm
F Height to top indicator	:	545 mm

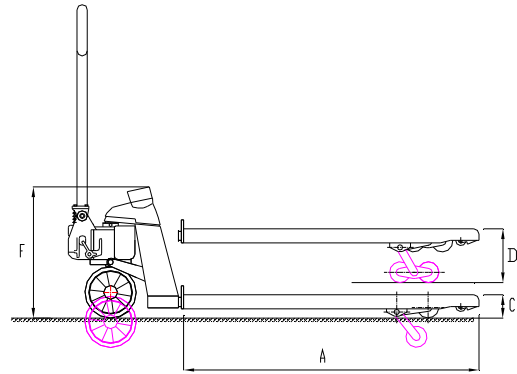

STANDARD SPECIFICATIONS

Weighing capacity	:	2200 kg
Tolerance	:	0.8% of full scale
Display	:	LCD, height 18 mm
Keypad	:	tare key, on / off key
Protection class	:	IP65
Steering wheels	:	rubber
Loading wheels	:	polyurethane, single
Colour	:	red (RAL 3000), epoxy painted
Own weight	:	58 kg
Battery	:	4 x 1.5V AA-batteries
Battery life	:	3000 on/off weighing cycles of three minutes: automatic switch-off after 3 minutes
Pump	:	quick lift

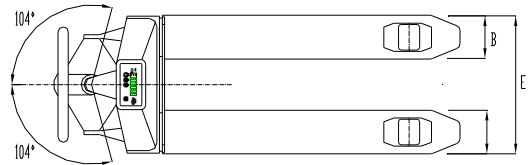

OPTIONS HAND PALLET TRUCK

- Tandem loading wheels in poly-urethane

RAVAS

RAVAS Europe B.V.

P.O. Box 2023
NL-5300 CA Zaltbommel
The Netherlands

☎ +31 – (0) 418 - 51 52 20

☎ +31 – (0) 418 - 51 53 20

info@ravas.com

www.ravas.com

Rev. 14.05.07