

S122

LIGHT INDUSTRIAL SCALE

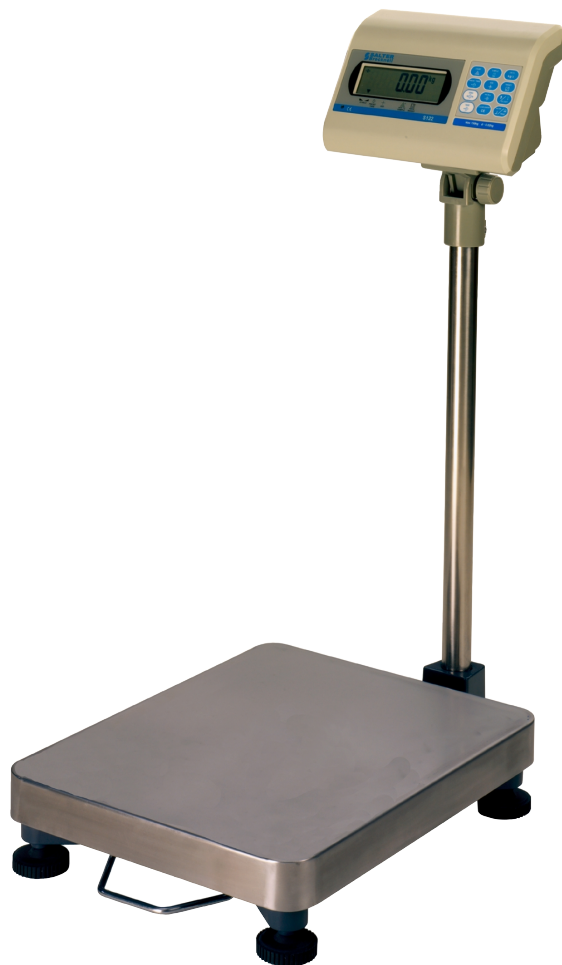

- simple to operate
- battery & mains power
- large back lit LCD display
- OIML approved 3000d
- affordable
- capacity from 60 kg to 300 kg
- counting & totalising functionality
- checkweighing with audio target alarm

S122

LIGHT INDUSTRIAL SCALE

Features & benefits

The S122 is a general purpose, self contained industrial platform scale available in a choice of capacities.

S122 offers an accurate, flexible and reliable weighing solution at an affordable price.

Ideally suited to a wide range of applications the S122 features basic weighing and in addition offers counting, checkweighing and totalling functions as standard.

Designed with the user in mind the S122 key functions have been kept as simple as possible to minimise the need for training and yet the standard programmable features give the S122 a flexibility often only found on more expensive machines.

The user can select the count function - and the S122 is preprogrammed to take samples of 10, 20, 50 or 100 pieces.

Select the checkweighing function in either weighing or counting operations and set low and/or high limits - and the S122 gives an audible and visible signal when the target is reached.

Totalling is also available in either weighing or counting mode and allows the operator to not only track the total quantities weighed or counted but also the number of transactions which have taken place.

The S122 has a tough die cast base frame with a hard wearing stainless steel top pan ensuring that the scale stands up to the rigours of light industrial usage.

S122 is supplied complete with a robust indicator which can be either column or desk mounted to suit the customers requirements. The indicator features a large backlit LCD display, ideal for use in poorly lit areas and is fitted with a tilt / swivel bracket to ensure that the display is always in the optimum position for the operator.

Flexibility is the keyword for the S122 - with a choice of three power options as standard. The S122 is supplied complete with a mains adaptor and a built in rechargeable battery pack. Alternatively the S122 can be powered from dry cell batteries as well.

Do not worry if the environment is dirty - the S122 comes complete with a detachable plastic indicator cover!

Specifications

Scale Capacities
3000d Approved
60 kg x 0.02 kg
150 kg x 0.05 kg
300 kg x 0.1 kg

6000d Non-Approved
60 kg x 0.01 kg
150 kg x 0.02 kg
300 kg x 0.05 kg

Display type
6 digit back-lit LCD
(25 mm high digits)

Operation temperature
-10° C to 40° C

Power
Mains
240V plug in 9V Mains adaptor.
(supplied as standard)

Battery
Internal rechargeable Lead Acid battery.
S122 will give up to 180 hours continuous usage between recharges.
(supplied as standard)

Six 1.5V D size, alkaline dry cell batteries.
S122 will give up to 480 hours continuous usage before batteries need replacing.
(batteries not included)

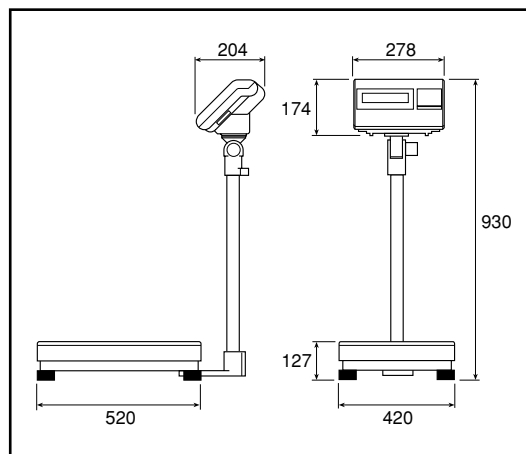

SALTER
Brecknell

P.O. Box 9533, Smethwick, West Midlands, B66 2TE
Tel: 0870 444 6132 Fax: 0870 010 2241
E-mail: sales@salterbrecknell.co.uk